



GlobalTop Technology Inc.

GPS Module Application Notes (MT3339 series)

Revision: A00

Technical Document



This document is the exclusive property of GlobalTop Tech Inc. and should not be distributed, reproduced, into any other format without prior permission of GlobalTop Tech Inc. Specifications subject to change without prior notice.

Copyright © 2012 GlobalTop Technology Inc. All Rights Reserved.

No.16 Nan-ke 9th Rd, Science-Based Industrial Park, Tainan, 741, Taiwan, R.O.C.

Tel: +886-6-5051268 / Fax: +886-6-5053381 / Email: sales@gtop-tech.com / Web: www.gtop-tech.com



Version History

Title: GlobalTop GPS Module Application Notes (MT3339 series)
Subtitle: GPS Module
Doc Type: Technical Document

Revision	Date	Editor	Description
A00	2012-08-03	Yingjie	First Release

Table of Contents

Table of Contents.....	3
Attention.....	4
Technical Support	5
1. Introduction	6
2. General Rules for Design-in	7
2.1 Circuit Design	7
2.1.1 Power supply VCC	7
2.1.2 VBACKUP backup battery.....	8
2.1.3 UART 0 (RX/TX) –Serial Interface	10
2.1.4 GND-Ground	10
2.1.5 Antenna Compliance Design	11
2.1.6 1PPS.....	14
2.1.7 3D_Fix.....	15
2.2 Layout Guideline	18
2.2.1 Layout underneath the GPS module.....	18
2.2.2 Keep far away from high profile or metal canned components	20
2.2.3 Placement	20
2.2.4 Trace.....	21
2.2.5 Ground Segmentation.....	22
2.2.6 Ground Plane	22
3. Thermal Profile for SMD Modules	24
*All the information in this sheet should be used only for Pb-free certification.	24
SMT Reflow Soldering Temperature Profile:	24
SMT Solder Mask:.....	24
Manual Soldering:	24
4. Troubleshooting.....	25
5. Contact.....	27
Appendix I: Super Capacitor Design	28
Appendix II: About 50 Ω Matching Line	29
Appendix III: UART to RS232 Interface.....	30
Appendix IV: UART to USB Interface.....	31
Appendix V: How to efficiently transfer 1PPS through extended distances.....	32
Appendix VI: Cautions on Reflow Soldering Process	37

Attention

Please read carefully before you start:

- If you use GPS receiver inside buildings, tunnels, or besides any huge objects, the GPS signals might be cut-off or disturbed. Please do not assume the receiver has malfunctioned.
- This application note provides the necessary guideline to successfully design a system using GPS modules. For detailed module specification, please refer to the corresponding datasheet of GPS module.
- GPS Module is an electrostatic sensitive device, please don't touch GPS module directly, please follow ESD safety rule when handling.
- For the first time, it is strongly recommended to test the device outdoors with open sky for at least 10 to 15 minutes to ensure full ephemeris data received.



Technical Support

If you have any technical problems or cannot find the required information in our documents, please feel free to contact us for technical support. Below is a list of information which you can provide that will be very useful to us in determining source of the problem and the necessary solution:

1. Your company name and website
2. Description about application and system
3. GPS module type
4. GPS firmware version
5. Description of the question or problems encountered, together with pictures or videos files
 - Test setup
 - The problem or issue shown in pictures

Technical contact information: support@gtop-tech.com

1. Introduction

GlobalTop has various GPS modules designed for many different applications.

The application note is compliant with the models listed below using MT3339 chip:

Stand alone GPS module: **FGPMMOSL3C (SL3C), Gmm-u2P**

Module built-in Patch Antenna: **FGPMMOPA6C (PA6C)**

Module built-in Patch Antenna and external EX_ANT pin: **FGPMMOPA6H (PA6H)**

Module built-in chip antenna: **Gms-u6b**



SL3C

Gmm-u2p

PA6C



PA6H



Gms-u6b

2. General Rules for Design-in

In order to obtain good GPS performances, there are some rules which require attentions for using GPS module.

2.1 Circuit Design

Compatible Mode: SL3C, Gmm-u2p, PA6C, PA6H, Gms-u6b

2.1.1 Power supply VCC

It is necessary to provide a clean and stable power supply for our GPS module in order to obtain good performances. Unstable power source will have a significant negative impact on the GPS performance. To achieve this, the Vcc ripple must be controlled under 50mV_{pp} . In addition, there are also some important suggestions for main power circuit design:

- (1). Add ferrite bead, power choke or low pass filter for power noise reduction
- (2). linear regulator is better than switch DC/DC power supplier in ripple
- (3). Use enough decoupling capacitors beside VCC for stable voltage.

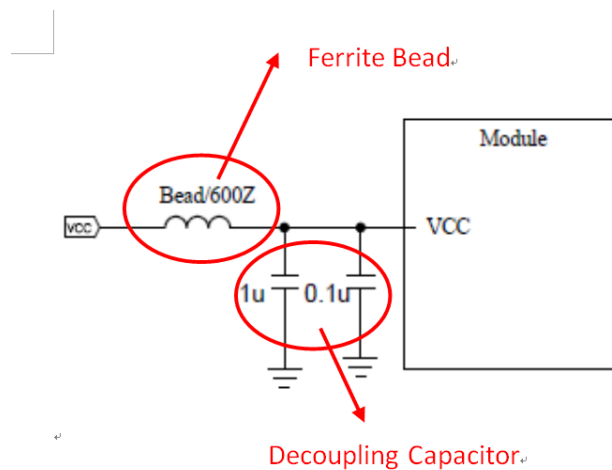

Power design for GPS module

2.1.2 VBACKUP backup battery

Compatible Mode: SL3C, Gmm-u2p, PA6C, PA6H, Gms-u6b

There are 2 applications for applied VBACKUP to GPS module.

Application 1:

Backup power is used for keeping RTC running and navigation data after the main power was turn off. For a short term VCC off, with backup power, the GPS module can have a faster TTFF, Time to First Fix, or hot start when next power on.

It is recommended to connect the module VBACKUP to a sustained power source (ex: Li-Ion rechargeable coin battery, super cap) for backup power. See figure for reference.

About super capacitor reference design, please refer to Appendix I: Super Capacitor Design.

GPS module is already built-in a charge circuit for the battery charging function, it will charge battery while GPS module working and that will extend the battery life.

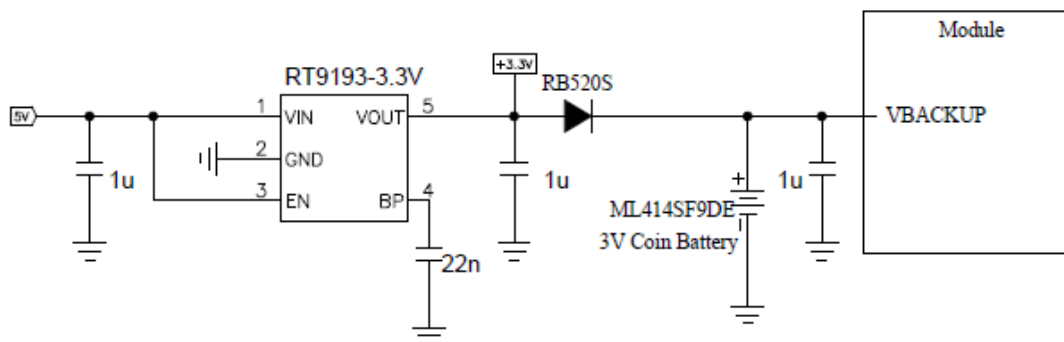

Using Coin Battery for GPS module

Application 2:

Since GPS module already built-in a charging circuit that also supply the VBACKUP a available voltage, the module still work fine if a external coin battery for VBACKUP is not installed.

Because VBACKUP power was not installed, the GPS module will perform a cold start every time it is powered on.

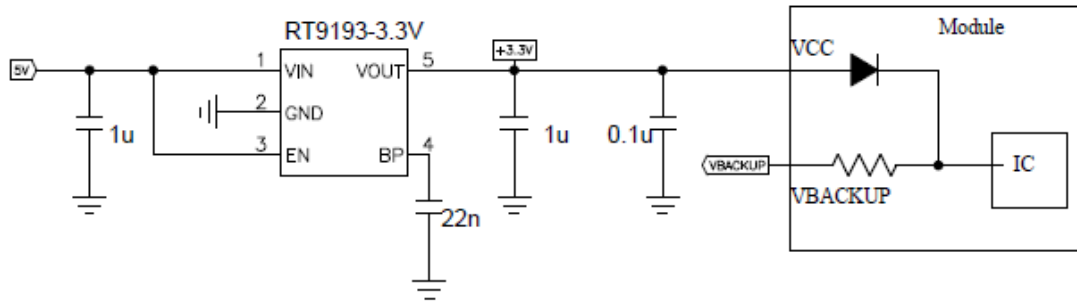

Built-in a charging circuit for GPS module

2.1.3 UART 0 (RX/TX) –Serial Interface

Compatible Mode: SL3C, Gmm-u2p, PA6C, PA6H, Gms-u6b

- (1). UART is the default interface (TTL level) that has the baud rate ranging from 4800 bps to 115200 bps.
- (2). Placing damping resistor on the RX and TX of the GPS module could limit the interference from host MCU or high speed digital logics. Fine tuning the damping resistor is required to suppress interference efficient. The damping resistor would be a chock coil as well.
- (3). Please leave RX open if it is not used as there is an internal pull-up to VCC.
- (4). Please don't connect diode(s) to RX/TX as it will decrease signal driving capability which might adversely affect RX/TX signal level (ex. no data output).
- (5). If RS232 logic-level is needed for any particular application, and then the level shifter is necessary. Please refer to "Appendix III: UART to RS232 Interface" for more information.
- (6). If USB logic-level is needed for any particular application. Please refer to "Appendix IV: UART to USB Interface" for more information.

2.1.4 GND-Ground

Compatible Mode: SL3C, Gmm-u2p, PA6C, PA6H, Gms-u6b

Make sure all GND pins of module are connected to a good ground plane.

Please refer to "2.2.5 Ground Segmentation".

2.1.5 Antenna Compliance Design

Compatible Mode: SL3C, Gmm-u2p, PA6H,

GPS antenna is a receiving device to acquire weak GPS signal from sky. Popular solution would be ceramic patch antenna because of its small form factor with low cost. There are two types of antennas, passive and active.

Passive antenna is with solely antenna itself such as Patch Antenna and Chip Antenna.

External antenna is a stand long device integrates with LNA, Patch Antenna and Cable to have high gain and good performance.

Antenna can be chosen according to radiation efficiency, radiation pattern, gain, bandwidth, form factor and cost. Make sure the ground plane is sufficient for the antenna to operate with good enough performance.

Design Patch antenna with GPS module.

- (1). Generally speaking, a $50\ \Omega$ Patch antenna will work good with GPS module just connect the Antenna_IN with a $50\ \Omega$ impedance trace.
- (2). please refer to “Appendix II: About $50\ \Omega$ Matching Line “for PCB impedance design”.
- (3). Pls keep the Patch antenna far away noise source such as switch power supplier and high speed digital logics.
- (4). The $50\ \Omega$ trace should keep as short as possible to reduce the chance to receive the noise from air and PCB. A simple direct line is recommended.
- (5). If need, a match circuit could be place between Patch antenna and GPS module. The match circuit should be discussed with module and Patch Antenna maker by case.

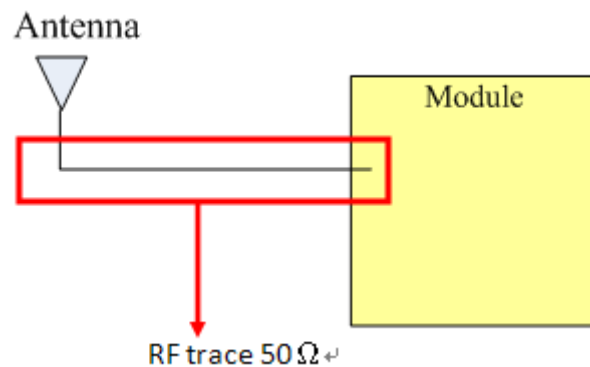

Antenna design for module

Select External Antennal architecture with GPS module.

For an external antenna, it needs a DC power to have it work properly.

A typical method is to feed a DC into the RF trace and the External Antenna can extract the DC from RF trace. Thus we can use the RF trace to transport both RF signal and DC volt.

We use a RF chock coil to couple the DC to RF trace to perform the mentioned method.

In GTOP module, we applied 3 kinds of architectures in our related module.

Please customer select the module carefully while applying the design with an External Antenna.

- Mode1 (**ex. SL3C**), the power supply for the External Antenna needs to be externally feed into pin VANT of the module and connect to Antenna_IN via a internal chock coil.
- Mode2 (**ex. Gmm-u2p**), the power supply needs to be externally provided and is connected directly to the External Antenna via chock coil.
Note: Chock Coil for reference: LQG15HS33NJ02D (Murata)
- Mode3 (**ex.PA6H**), the power supply comes from VCC via an antenna supervise circuit to monitor the status of DC current and limit the supplied current (over current protection). Typically, the current is limited if current >30mA.
The circuit also auto switch RF signal from internal Patch Antenna to External Antenna when connect an External Antenna.

Module \ Mode	SL3C	Gmm-u2p	PA6H
Model 1 (Internal chock coil)	✓		
Model 2 (External chock coil)		✓	
Model 3 (built-in Antenna Supervisor)			✓

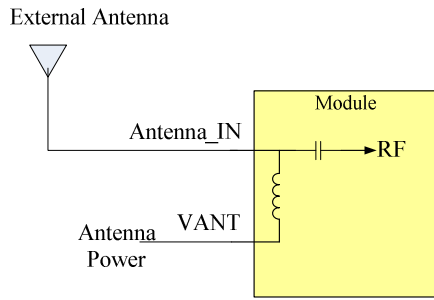

Model 1

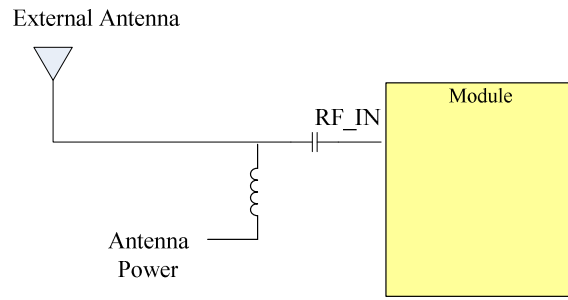

Model 2

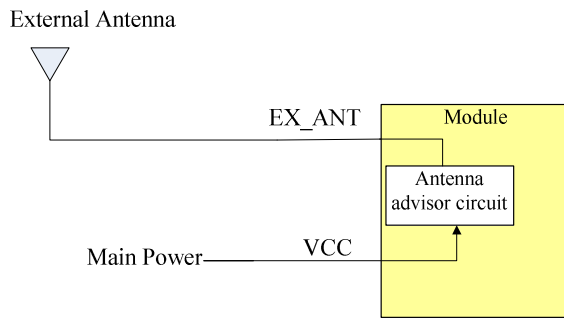

Model 3

2.1.6 1PPS

Compatible Mode: SL3C, Gmm-u2p, PA6C, PA6H, Gms-u6b

1PPS signal is an output pulse signal used for timing application, its electronic characteristic are listed below:

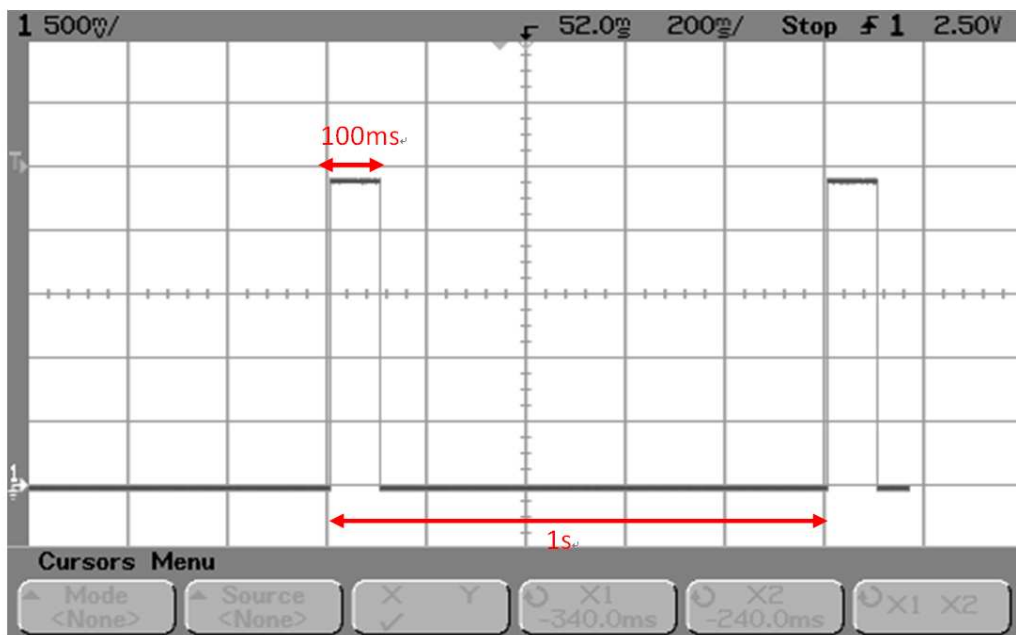

1PPS signal and its pulse width with 100ms duration

Low Voltage level: 0~0.4V

High Voltage level: 2.8~3.1V

Duration: 100ms (Firmware customization for duration is available)

Period: 1s

Accuracy (jitter):10ns

Free run 1PPS output before 3D_FIX

Standard GPS module will output the 1pps after the module is 3D_FIX.

A customize firmware could set the 1PPS plus out as soon as power-on disregard to 3D_Fix or not.

Please be noted that the accuracy before 3D_Fix on the 1PPS is a free run plus and will real lock until GPS 3D_Fix.

Cable delay compensation

For a timing application, it could be connected to a cable for a long distance connection (~300m).

Please refer to Appendix V for more information on 1PPS signal transmission delay.

Please also be noted that the delay caused by the cable could be compensated with firmware setting.

Please contact us if that is useful for customer.

LED indicator for 1PPS

Customer can also connect a LED with a 330 Ω to GND for the indication of specific indicator.

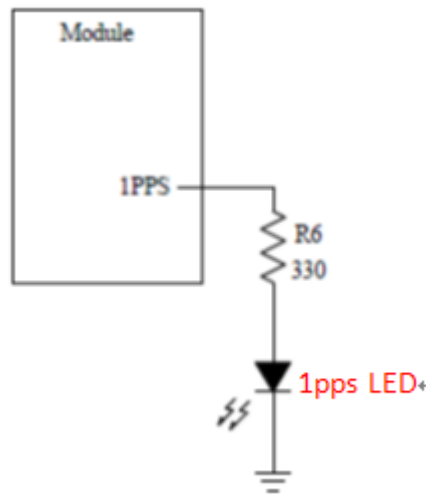

1PPS signal design for IO

2.1.7 3D_Fix

Compatible Mode: SL3C, Gmm-u2p, PA6C, PA6H, Gms-u6b

3D_Fix signal is an output pulse signal used for GPS fix application, its electronic characteristic are listed below:

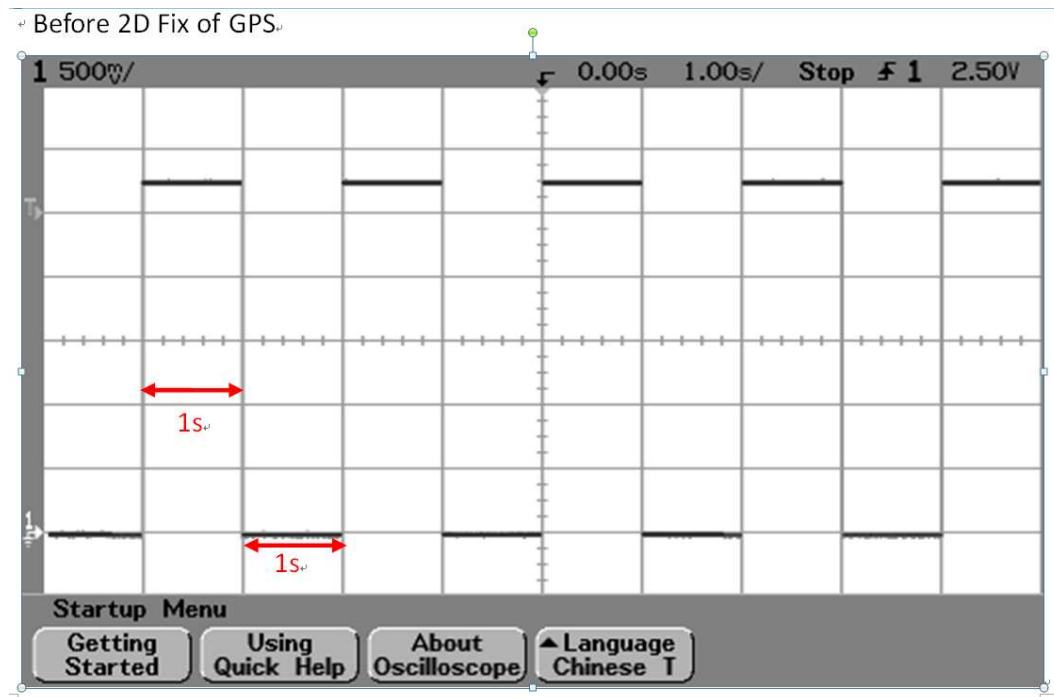

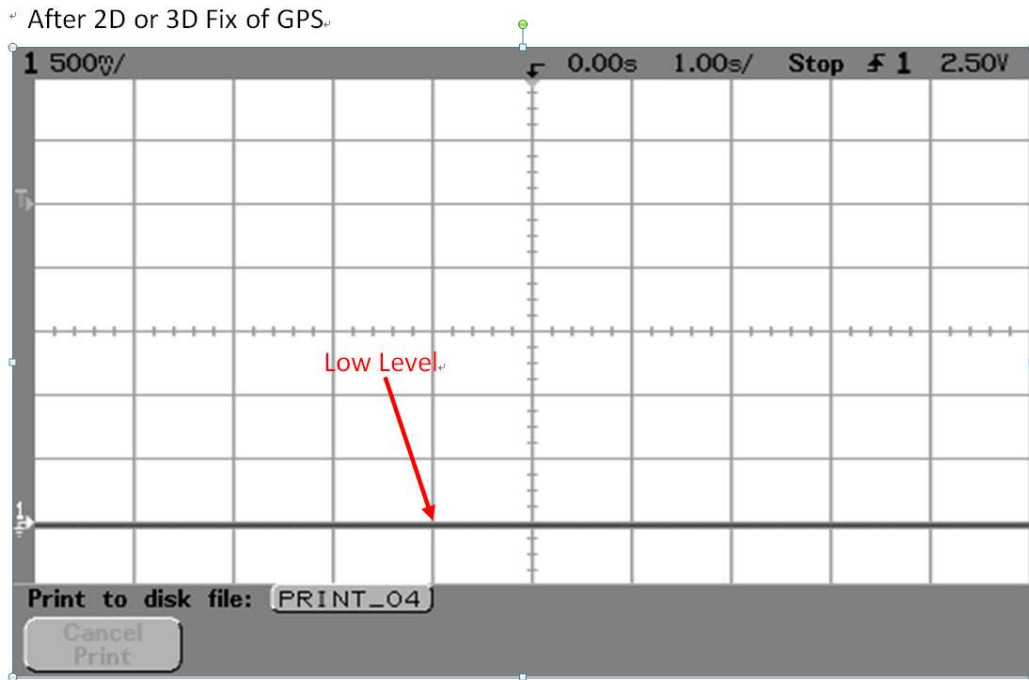

Low Voltage level: 0~0.4V

High Voltage level: 2.8~3.1V

Source current: 14 mA, Sink current 14 mA

Before 2D Fix:

Duration: High level with one-second and Low level with one-second

Period: 2s

(Firmware customization for duration is available)

After 2D or 3D Fix:

Duration: Continuously output low-level

(Firmware customization for duration is available)

Customer can also connect a LED with a 330Ω to GND for the indication.

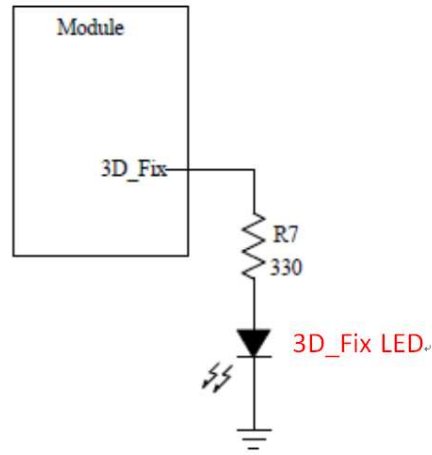

3D_Fix signal design for IO

Note: Please do not connect a LED with 330Ω from VCC .

That will cause an internal function fail of GPS module.

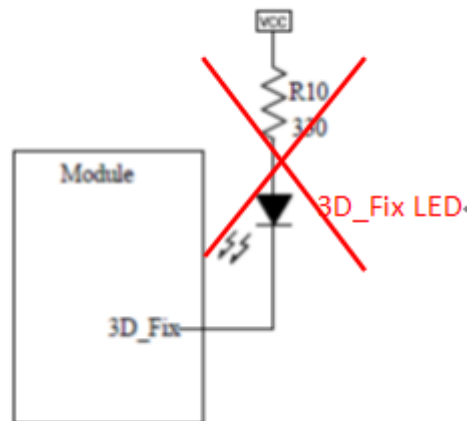

NG

2.2 Layout Guideline

Please follow the layout criteria to design a system using GPS module.

2.2.1 Layout underneath the GPS module

Compatible Mode: SL3C, Gmm-u2p, PA6C, PA6H, Gms-u6b

GPS signal is very weak signal level around $-160\text{dBm} \sim 130\text{dBm}$. Any noise or harmonic will decrease the quality of GPS. In modern GPS product, it almost includes LCD, MCU, High Speed digital and RF system (BT, Wi-Fi, DVB-T...). In order to minimize the influence of mentioned noise to GPS module, please customer don't place any trace underneath the GPS module. In other word, give GPS module a clean GND plane is very important.

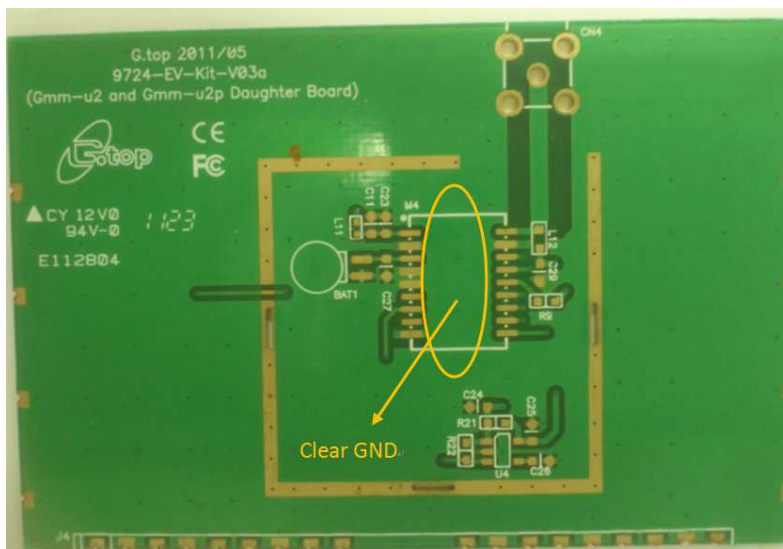

GPS on a clean GND plane

For module PA6H and PA6C, place a hold according to the location of RF feeding pin in module. The hole will keep the RF feeding pin far away customer's GND plane that will minimize the loss caused by the coupling of antenna signal to GND.

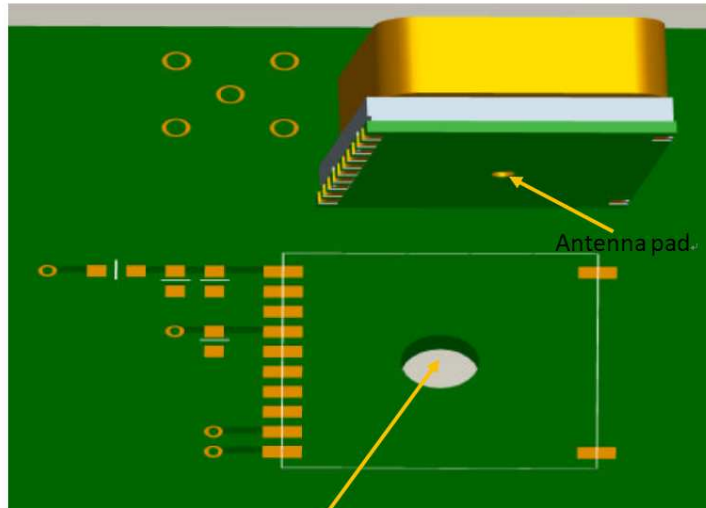

Note..

Place one hole (diameter=3.0mm) under this module as part of the antenna pad and please don't let any trace and via pass the area..

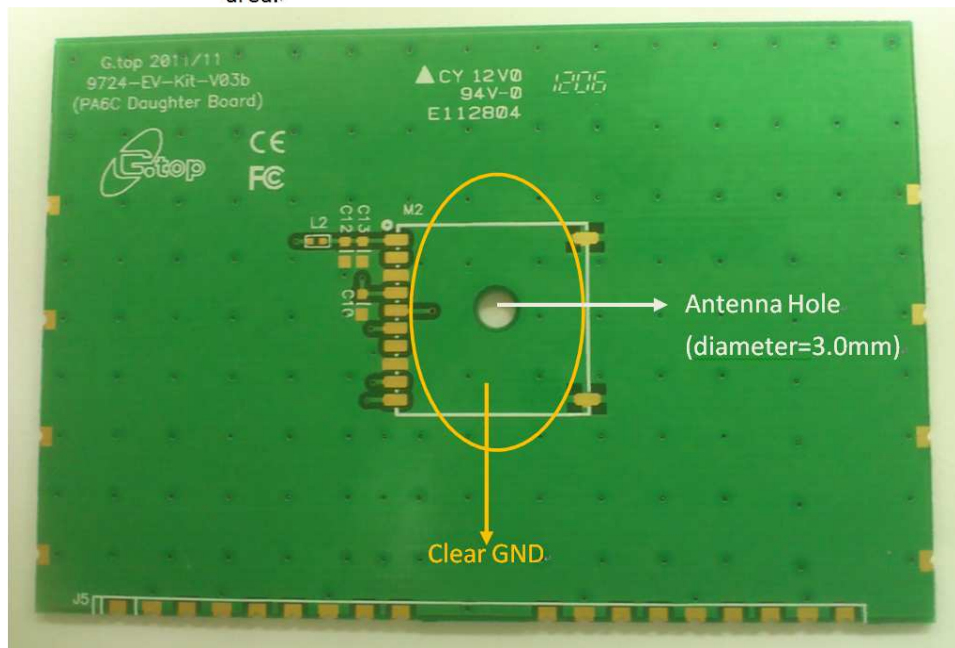

GPS on a clean GND plane and antenna hole

2.2.2 Keep far away from high profile or metal canned components

Compatible Mode: PA6C, PA6H, Gms-u6b



For PA6C, PA6H, It is better to place GPS module far away a high profile component especially with metal case enclosed products such as E-CAP. That will cause the distortion of the Antenna field pattern and the worst case will decrease the GPS signal up to ~10dB.

2.2.3 Placement

Compatible Mode: SL3C, Gmm-u2p, PA6C, PA6H, Gms-u6b

Place the decoupling capacitors close to GPS module

Place the damping resistors close to GPS module

Do not place:

- GPS module close to high-speed digital processing circuitry

- GPS module close to high-current switching power circuitry

- GPS module close to clock sources circuitry

- Patch Antenna close to the high profile metal case component as **2.2.2** said.



2.2.4 Trace

Compatible Mode: SL3C, Gmm-u2p, PA6C, PA6H, Gms-u6b

- (1). The USB differential signals should be trace close and equal-length for minimum radiation and noise immunity.
- (2). Please have the RF traces had the character impedance of 50 ohm for good impedance matching.
- (3). Any right angle turn in trace routing should be accomplished with two 135 degree turn or an arc turn

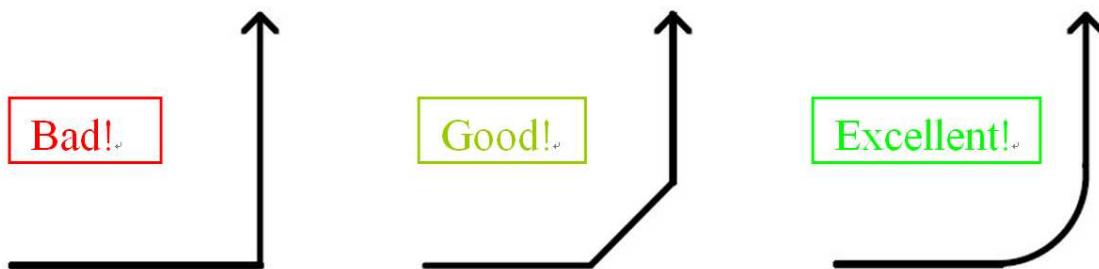

It is better to have independent trace of power source for any device

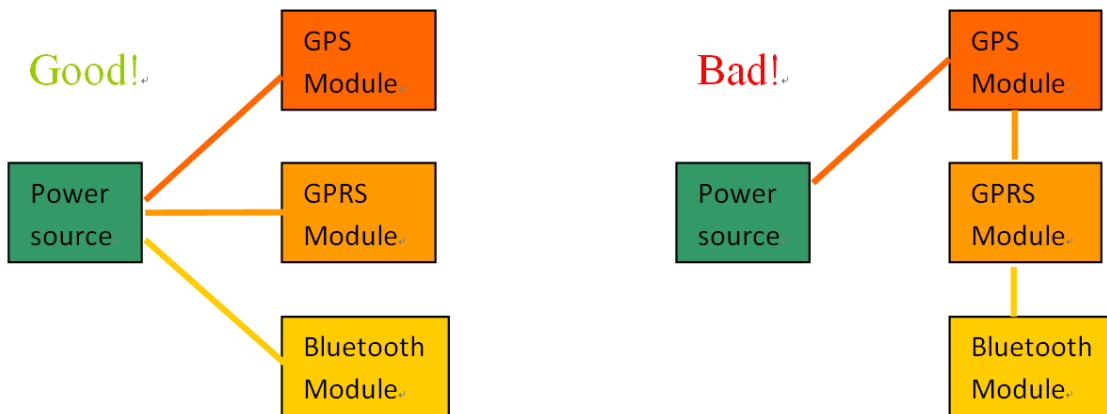

2.2.5 Ground Segmentation

Compatible Mode: SL3C, Gmm-u2p, PA6C, PA6H, Gms-u6b

The separation of ground between GPS module and the rest of the system is recommended to avoid interference. If this is not possible, it is best to follow these typical rules: segmentation of ground between digital and analogue system, high current and low current system, and different radiation systems in general (such as GPS and GPRS).

One way to segment the ground is to place digital and noise component at one corner of the board, while placing analog and quiet components at the opposite corner of the board. Make sure there is no crossing of microstrip or current between the two component sets and grounds of each sets are contacted in one point only.

Another way to do this is the place the two different sets at different layers of the board, while the ground of each layer is contacted in one point only (preferable at border of the board).

2.2.6 Ground Plane

Compatible Mode: PA6C, PA6H, Gms-u6b

For PA6C and PA6H, a large GND plane direct underneath the module could enhance the magnetic-field line of the antenna for better GPS signal reception. Typical it will improve ~2dB as maximum.

It is strongly recommended to have a ground plane designed underneath the GPS module as big as possible.

The recommended thickness for the ground layer is 0.5 to 1 OZ (0.0175 to 0.035 mm)

It is best to place the ground plane on the top layer of the PCB, directly underneath the GPS module as the figure below shows:

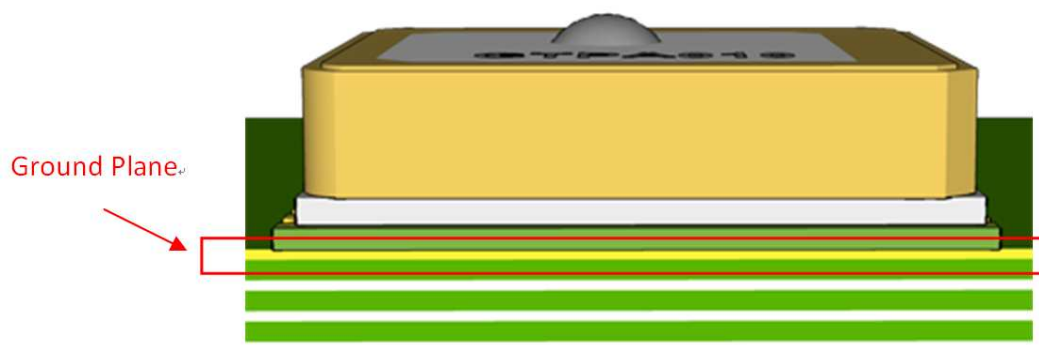

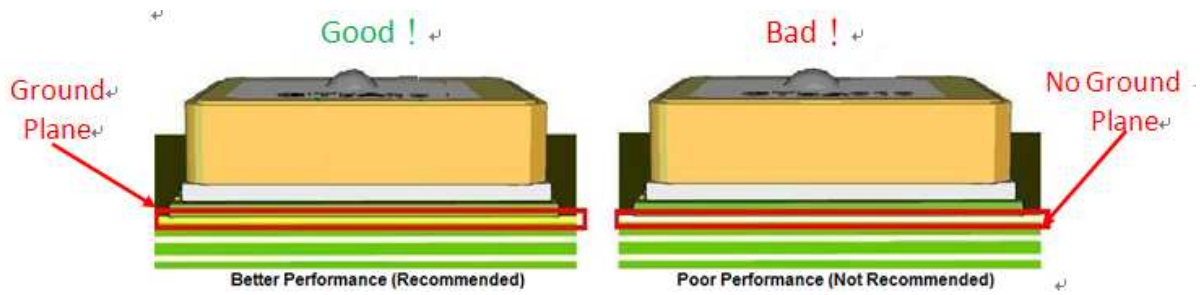

Ground Plane for FR4 Design

For module **Gms-u6b**, built-in Chip Antenna, a special ground plane is required for chip antenna reception performance improvement.

As shown in the figure, the area circled according to the antenna area of module should be kept Ground-Clarence all layers.

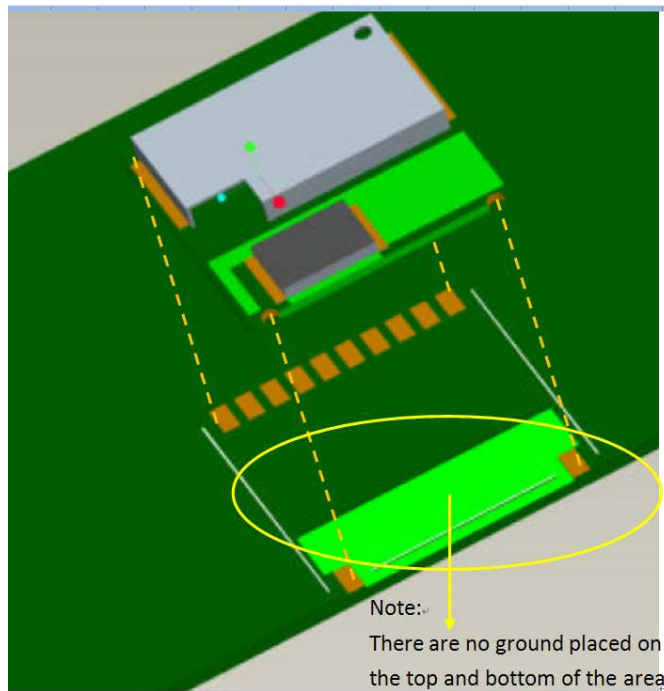

3. Thermal Profile for SMD Modules

(Reference Only)

*All the information in this sheet should be used only for Pb-free certification.

SMT Reflow Soldering Temperature Profile:

Average ramp-up rate (25 ~ 150°C): 3°C/sec. max.

Average ramp-up rate (270°C to peak): 3°C/sec. max.

Preheat: 175 ± 25°C 、 60 ~ 120 seconds

Temperature maintained above 217°C: 60~150 seconds

Peak temperature: 250 +0/-5°C 、 20~40 seconds

Ramp-down rate: 6°C/sec. max.

Time 25°C to peak temperature: 8 minutes max.

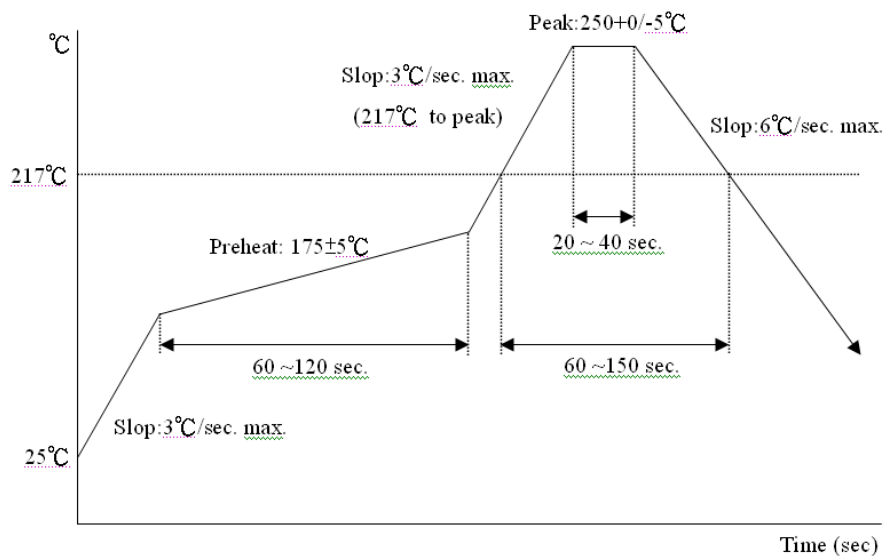

SMT Solder Mask:

Please use the dimension of PCB pad as reference and shrink the size by 0.1 to 0.2 mm and use that as layout for paste mask. (For PCB pad layout, please see “Recommended PCB pad layout” on individual GPS module data sheet)

Manual Soldering:

Soldering iron: Bit Temperature: Under 380°C Time: Under 3 second.

4. Troubleshooting

How to check for the working status of GPS module?

The first thing to check for is the NMEA sentence output through TX by using various application tools. For example: you can use windows default tool - WinXP Hyperterminal, or you can use other GPS application program to check for GPS status.

If there is no NMEA output, this indicates the module is currently not working. Please double check your schematic design. Down below we listed some of the possible items to check for your reference:

Item 1: VCC

The voltage should be kept between 3V to 4.3V. **(Typical : 3.3V), Please double-check.**

Item 2: VBACKUP

The voltage should be kept between 2.0V~4.3V. **(Typical : 3.0V)**. If the module has no battery for the VBACKUP, the pin still could be measure a voltage by built-in charge circuit. It is recommended that a sustain power for VBACUP is supplied to keep RTC time and navigation data, **Please double-check**

Item 3: 3D-FIX

If all the measurements are within the specifications, please also measure 3D-FIX signal. Before 2D Fix, **the pin should output one-second high-level signal follow with one-second low-level signal.**

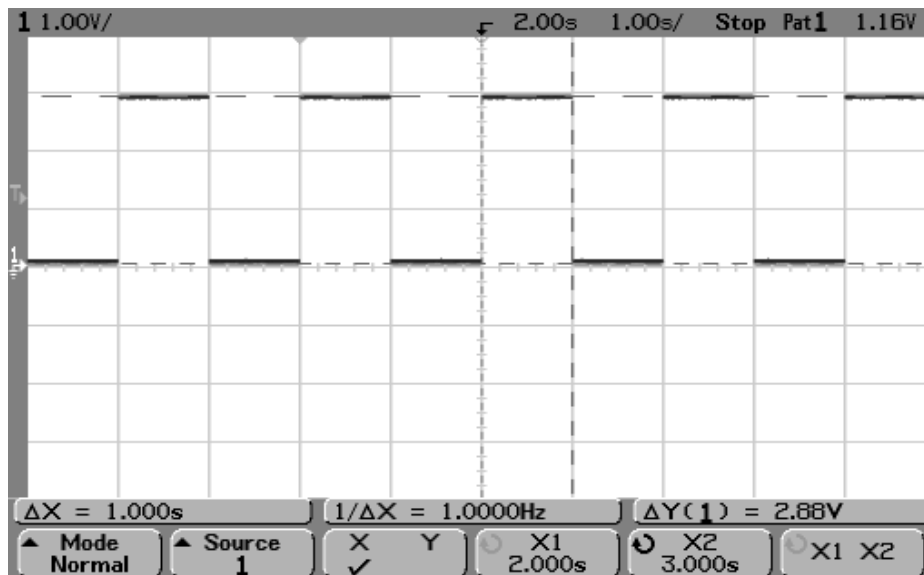

Item 4: TX0

The UART transmitter of the module, it outputs the GPS NMEA information for application.

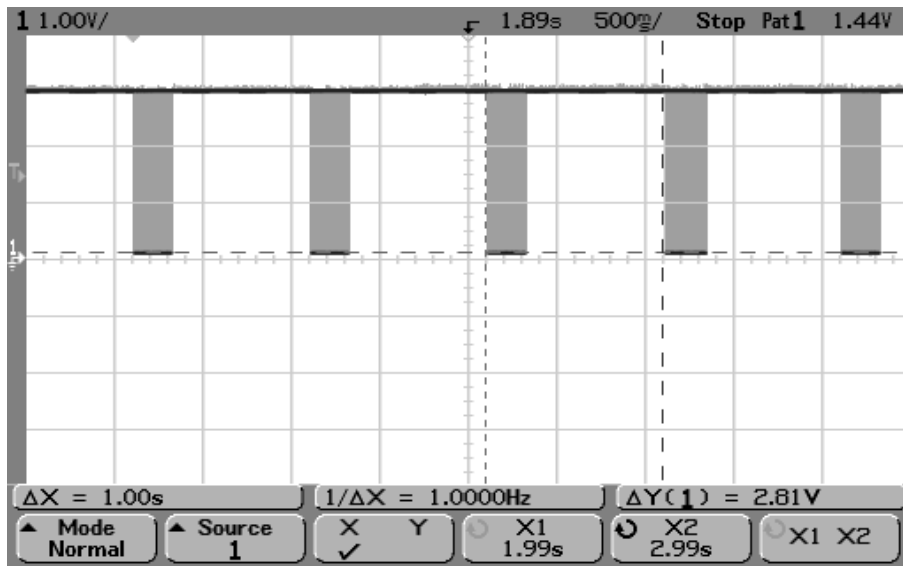



5. Contact

For help or further information, please contact us via the following methods:

GlobalTop Technology Inc.

Tainan Science-Based Industry Park Headquarter:

Address: No.16 Nan-ke 9th Road Science-based Industrial Park, Tainan 74147,
Taiwan

Tel: +886-6-505-1268

Fax: +886-6-505-3381

Sales Email: sales@gtop-tech.com

Technical Support Email: support@gtop-tech.com

Appendix I: Super Capacitor Design

About Super Capacitors

Super capacitors have a useful life-time similar to aluminum electrolytic capacitors. The life of a super capacitors capacitor is largely dependent on the operating temperature, humidity, applied voltage, current and backup time requirements. Therefore, the life of a super capacitor is determined based on the backup time set by the customer.

How to calculate the backup time

The example below teaches how to calculate the backup time.

$$T = C (V_0 - V_1) / (I + I_L)$$

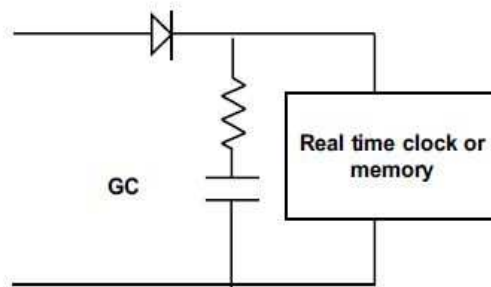

Capacitor's voltage

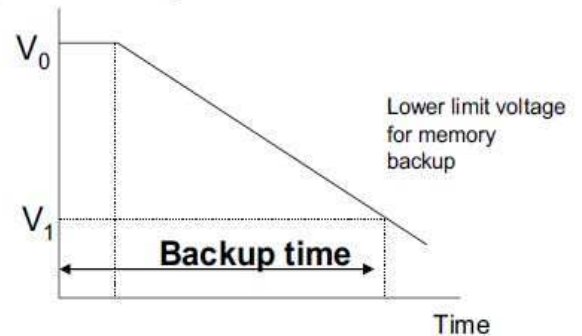

Example:

$$V_0 = 2.5V, \quad V_1 = 1.8V, \quad I = 10\mu A, \quad C = 0.2F$$

$$\begin{aligned} T &= 0.2 (2.5 - 1.8) / (10 \text{ e-}6 + 0.2 \times 10^{-6}) \\ &= 0.14 / 10.2 \times 10^{-6} \\ &= 13,725 \text{ seconds} \\ &= 3.8 \text{ hours} \end{aligned}$$

T: Backup time (second)
C: Capacitance of Gold Capacitor (F)
 V_0 : Applied voltage(V)
 V_1 : Lower limit voltage for memory backup(V)
I: Current during backup(A)
 I_L : Leakage current(A) about 0.2 μ A

Appendix II: About 50 Ω Matching Line

We used AppCAD tool for 50 Ω impedance calculation of RF line and made a table for layout reference.

RF line width (W)	PCB FR4 Thickness (H)	Dielectric parameter	Copper Thickness an ounce
1.8mm	1mm	4.6	0.035mm

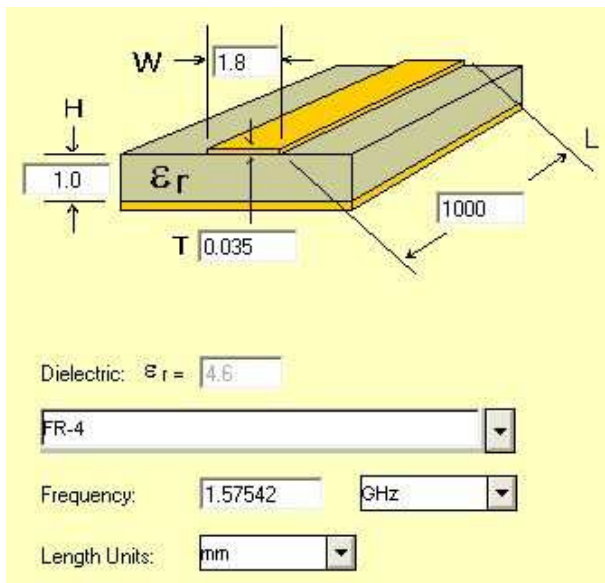

Notice:

For multiple-layer layout, designer could place a ground layer in 2nd layer to minimize the trace width in specific PCB (such FR4) and impedance.

For impedance calculation, free software to calculate trace width or impedance is available.

Please refer to the website for one such software:

<http://web.awrcorp.com/Usa/Products/Optional-Products/TX-Line/>

Appendix III: UART to RS232 Interface

Typically RS232 or USB interface is required to connect GlobalTop GPS module directly to the PC for communication. Majority of GlobalTop modules uses a set of communication port in TTL-logic (and a newer ones have support for direct USB connection) and a bridge IC is needed for conversion to RS232 level.

Please note the supported baud-rates are: 4800, 9600, 14400, 19200, 38400, 57600, and 115200 bps.

Please refer to the reference circuits below for such conversion: (using SP3320 IC as an example)

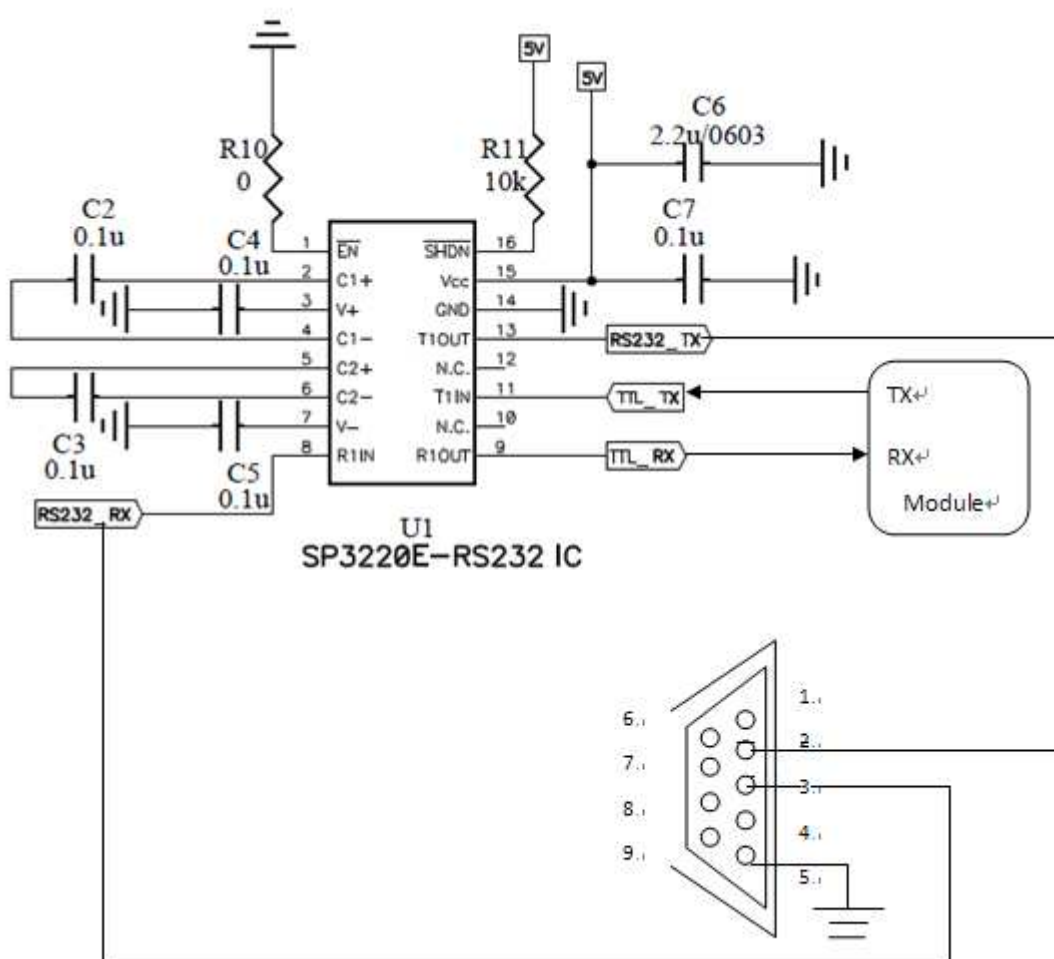

Appendix IV: UART to USB Interface

If the GlobalTop module you have chosen does not contain USB interface or if you do not wish to use the integrated USB interface (perhaps due to driver or other concerns), it is possible to connect it to an external USB IC and further enhance the transferring speed by using a one capable of USB 2.0 interface. Once the driver for the chosen USB Bridge IC is successfully installed for Windows or other operating system, the USB Bridge IC will be automatically recognized as a com port within the operating system.

Note: proper driver must be installed or else the operating system will not be able to recognize the device!

Please refer to the reference circuits below for such conversion: (using CP2102 IC as an example)

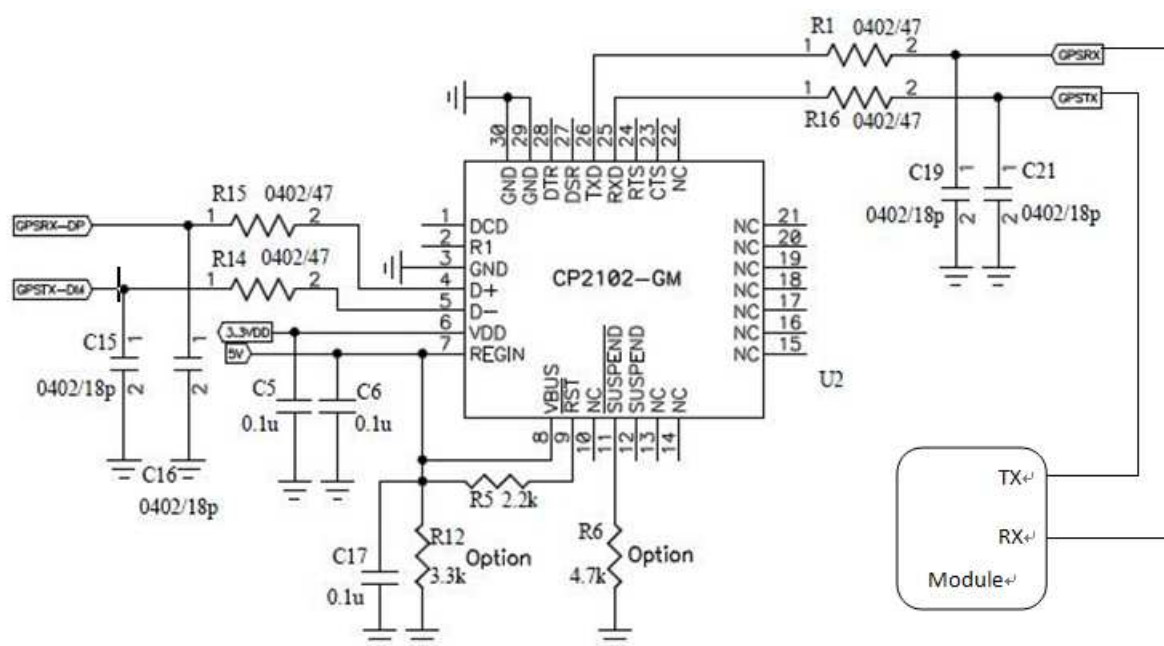

(The Pin29 and Pin30 are the bottom ground pads which not be listed in IC data sheet, customer could create the decal omitted this 2 pin)

Appendix V: How to efficiently transfer 1PPS through extended distances

There are several things to watch out for when transferring 1PPS through long distances which will result in 1PPS signal degradation, noise and delays if proper attentions are not being paid. As the 1PPS signal passes through the communication cable, matching resistance must be implemented to prevent wave form distortions. Depending on user's application, OPA can be added to effectively control the accuracy of the voltage level determination for the 1PPS signal.

When using 1PPS signal to synchronize time, the OPA chosen should have a **high slew rate** property to prevent large delay in the 1PPS. The accuracy level of 1PPS for GlobalTop GPS module is within 100ns (same for majority of MTK GPS modules). The reference design below can help improving this accuracy to within 80ns.

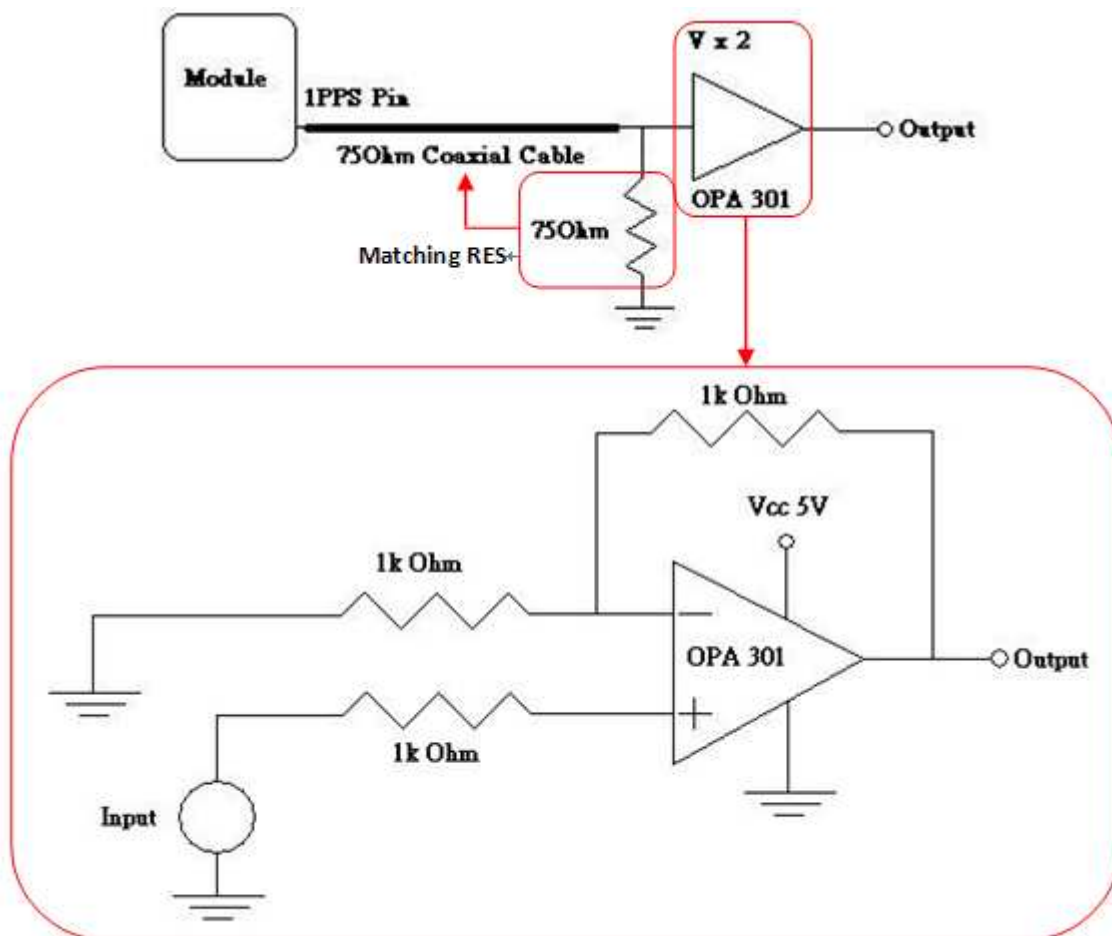

1PPS Delay Time :

When using coaxial cable for long distances communication using OPA amplification, please pay close attention on the time delay caused by the coaxial cable and rising time of the wave form affected by OPA's SR. A brief explanation for this is provided below:

The model number for the coaxial cable is RG6U, where the figure below shows its specification.

CONSTRUCTION

Item		A.Q.L.	Description
Conductor	No./mm	1.02 (± 0.025)	Copper clad steel
	1.02 CCS		
Insulation	No./mm	4.57 (± 0.20)	Foamed PE insulation
	4.57		
Shield	B-APA	64 (±2); 0.16 (± 0.01)	Bonded double aluminium foil shield
	64/0.16(AL)		Aluminium wire braid shield
	APA	48 (±2); 0.16 (± 0.01)	Double aluminium foil shield
	48/0.16(AL)		Aluminium wire braid shield
Jacket	No./mm	7.20 (± 0.30)	Black flame retardant PVC jacket
	7.20 PVC		

DESIGN

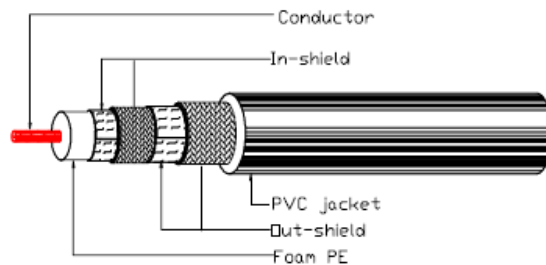

CHARACTERISTICS

ITEM	Description	Standards	
Conductor Resistance	20°C, conductor DC resistance	<10Ω/100M	
Capacitance		53.2 ± 5pF/M	
Velocity Ratio		83 ± 3%	
Characteristic Impedance	20°C, 200MHz	75Ω ± 3Ω	
Return Loss	20°C, 5 --- 200MHz	>20dB	
Attenuation	20°C -dB/100M (± 10%)	55MHz	4.94
		211MHz	9.43
		400MHz	13.12
		870MHz	19.99
		1000MHz	21.46
		2000MHz	31.82

The delay time cause by the cable:

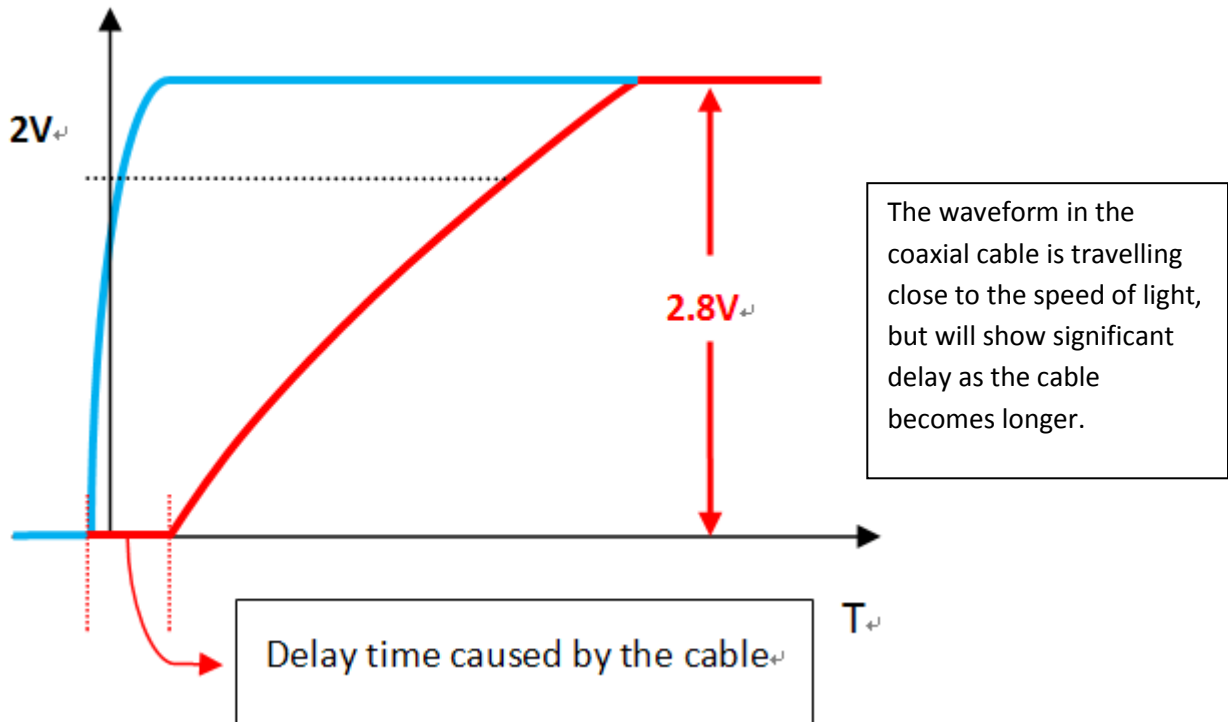

How to calculate the delay time of the communication cable with the length of “N”

The simplest method to calculate this is to have a good grasp on the relationship between:

1. The speed of the waveform
2. The distance of the wave form traveled
3. The delay time

$$\frac{\ell}{u_p} = T$$

ℓ = Distance of the wave form traveled (m)

u_p = Speed of the waveform (m/s)

T = Delay Time (ns)

If the speed of the waveform (in coaxial cable) is unknown, it is possible to use a short sip of coaxial cable to test for this. For example, the signal travelling in 1 meter of coaxial cable can have its delay time measured by the oscilloscope as 5ns, and consequently the μ_p will be $2 * 10^8$ (m/s).

If the value of resistance and inductance for the coaxial cable is known, then perhaps μ_p (m/s) can be calculated as well.

$$\mu_p = \frac{1}{\sqrt{LC}}$$

Moreover, fundamentals of electromagnetics such as RLCG parameters for the coaxial cable (including resistance, inductance, capacitance, and conductance), together with the inner and outer diameter of the cable, can be used in combination to perform theoretical calculations.

Waveform rising time caused by OPA

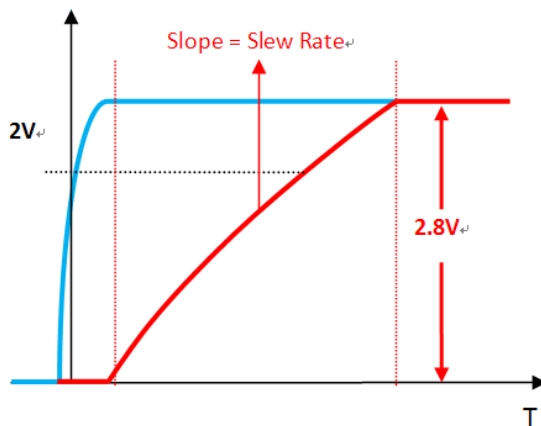

The left figure shows Slew Rate: which is the time needed for rising waveform. When the SR (V/ μ sec) of OPA is higher, the rising time will be shortened as well.

Recommended OPA

If inadequate OPA is chosen (with low slew rate), the delayed caused by waveform rising time will be significantly longer than the delay in time caused by the coaxial wire.

We recommend using **OPA301** to decrease the waveform rising time

Specification of OPA301:



- ◎Low Power : 9.5mA (Typ) on 5.5V
- ◎Single Power : 2.7V ~ 5.5V
- ◎High Slew Rate : 80 V/ μ sec
- ◎Tiny Packages : MSOP and SOT23

Voltage degradation of communication cable

We have tested a 10m long coaxial cable and only insignificant amount of voltage degradation is observed. Users should not be concerned with this issue.

Appendix VI: Cautions on Reflow Soldering Process

	Details	Suggestions	Notes
1	Before proceeding with the reflow-soldering process, the GPS module must be pre-baked.	Pre-bake Time: 6 Hours @ 60°±5°C or 4 Hours @ 70°±5°C	The maximum tolerated temperature for the tray is 100°C. After the pre-baking process, please make sure the temperature is sufficiently cooled down to 35°C or below in order to prevent any tray deformation.
2	Because PCBA (along with the patch antenna) is highly endothermic during the reflow-soldering process, extra care must be paid to the GPS module's solder joint to see if there are any signs of cold weld(ing) or false welding.	The parameters of the reflow temperature must be set accordingly to module's reflow-soldering temperature profile.	Double check to see if the surrounding components around the GPS module are displaying symptoms of cold weld(ing) or false welding.
3	Special attentions are needed for PCBA board during reflow-soldering to see if there are any symptoms of bending or deformation to the PCBA board, possibility due to the weight of the module. If so, this will cause concerns at the latter half of the production process.	A loading carrier fixture must be used with PCBA if the reflow soldering process is using rail conveyors for the production.	If there is any bending or deformation to the PCBA board, this might causes the PCBA to collide into one another during the unloading process.
4	Before the PCBA is going through the reflow-soldering process, the production operators must check by eyesight to see if there are positional offset to the module, because it will be difficult to readjust after the module has gone through reflow-soldering process.	The operators must check by eyesight and readjust the position before reflow-soldering process.	If the operator is planning to readjust the module position, please do not touch the patch antenna while the module is hot in order to prevent rotational offset between the patch antenna and module

Note: References to patch antenna is referred to GPS modules with integrated Patch-on-top antennas (PA/Gms Module Series), and may not be applicable to all GPS modules.

	Details	Suggestions	Notes
5	Before handling the PCBA, they must be cooled to 35°C or below after they have gone through the reflow-soldering process, in order to prevent positional shift that might occur when the module is still hot.	<ol style="list-style-type: none"> 1. Can use electric fans behind the Reflow machine to cool them down. 2. Cooling the PCBA can prevent the module from shifting due to fluid effect. 	It is very easy to cause positional offset to the module and its patch antenna when handling the PCBA under high temperature.
6	<ol style="list-style-type: none"> 1. When separating the PCBA panel into individual pieces using the V-Cut process, special attentions are needed to ensure there are sufficient gap between patch antennas so the patch antennas are not in contact with one another. 2. If V-Cut process is not available and the pieces must be separated manually, please make sure the operators are not using excess force which may cause rotational offset to the patch antennas. 	<ol style="list-style-type: none"> 1. The blade and the patch antenna must have a distance gap greater than 0.6mm. 2. Do not use patch antenna as the leverage point when separating the panels by hand. 	<ol style="list-style-type: none"> 1. Test must be performed first to determine if V-Cut process is going to be used. There must be enough space to ensure the blade and patch antenna do not touch one another. 2. An uneven amount of manual force applied to the separation will likely to cause positional shift in patch antenna and module.
7	When separating panel into individual pieces during latter half of the production process, special attentions are needed to ensure the patch antennas do not come in contact with one another in order to prevent chipped corners or positional shifts.	Use tray to separate individual pieces.	It is possible to chip corner and/or cause a shift in position if patch antennas come in contact with each other.

Note: References to patch antenna is referred to GPS modules with integrated Patch-on-top antennas (PA/Gms Module Series), and may not be applicable to all GPS modules.

Other Cautionary Notes on Reflow-Soldering Process:

1. Module must be pre-baked **before** going through SMT solder reflow process.
2. The usage of solder paste should follow “first in first out” principle. Opened solder paste needs to be monitored and recorded in a timely fashion (can refer to IPQC for related documentation and examples).
3. Temperature and humidity must be controlled in SMT production line and storage area. Temperature of 23°C, 60±5% RH humidity is recommended. (please refer to IPQC for related documentation and examples)
4. When performing solder paste printing, please notice if the amount of solder paste is in excess or insufficient, as both conditions may lead to defects such as electrical shortage, empty solder and etc.
5. Make sure the vacuum mouthpiece is able to bear the weight of the GPS module to prevent positional shift during the loading process.
6. Before the PCBA is going through the reflow-soldering process, the operators should check by eyesight to see if there are positional offset to the module.
7. The reflow temperature and its profile data must be measured before the SMT process and match the levels and guidelines set by IPQC.
8. If SMT protection line is running a double-sided process for PCBA, please process GPS module during the second pass only to avoid repeated reflow exposures of the GPS module. Please contact GlobalTop beforehand if you must process GPS module during the 1st pass of double-side process.

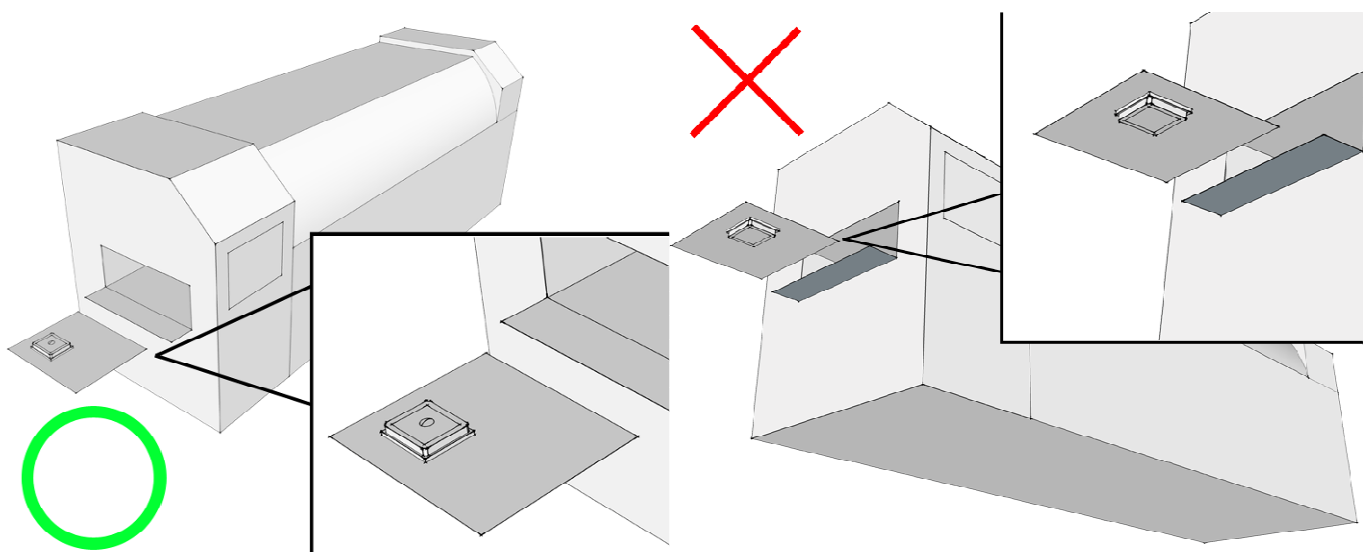

Figure 6.2: Place GPS module right-side up when running reflow-solder process, do not invert.

9. Module must be pre-baked **before** going through SMT solder reflow process.
10. The usage of solder paste should follow “first in first out” principle. Opened solder paste needs to be monitored and recorded in a timely fashion (can refer to IPQC for related documentation and examples).
11. Temperature and humidity must be controlled in SMT production line and storage area. Temperature of 23°C, 60±5% RH humidity is recommended. (please refer to IPQC for related documentation and examples)
12. When performing solder paste printing, please notice if the amount of solder paste is in excess or insufficient, as both conditions may lead to defects such as electrical shortage, empty solder and etc.
13. The reflow temperature and its profile data must be measured before the SMT process and match the levels and guidelines set by IPQC.

Manual Soldering

Soldering iron:

Bit Temperature: Under 380°C Time: Under 3 sec.

Notes:

1. Please do not directly touch the soldering pads on the surface of the PCB board, in order to prevent further oxidation
2. The solder paste must be defrosted to room temperature before use so it can return to its optimal working temperature. The time required for this procedure is unique and dependent on the properties of the solder paste used.
3. The steel plate must be properly assessed before and after use, so its measurement stays strictly within the specification set by SOP.
4. Please watch out for the spacing between soldering joint, as excess solder may cause electrical shortage
5. Please exercise with caution and do not use extensive amount of flux due to possible siphon effects on neighboring components, which may lead to electrical shortage.
6. Please do not use the heat gun for long periods of time when removing the shielding or inner components of the GPS module, as it is very likely to cause a shift to the inner components and will leads to electrical shortage.